

This article was downloaded by:

On: 19 January 2011

Access details: *Access Details: Free Access*

Publisher *Taylor & Francis*

Informa Ltd Registered in England and Wales Registered Number: 1072954 Registered office: Mortimer House, 37-41 Mortimer Street, London W1T 3JH, UK



International Journal of Polymeric Materials

Publication details, including instructions for authors and subscription information:

<http://www.informaworld.com/smpp/title~content=t713647664>

Catalytic Reaction by Hydrotalcites - (I): Polymerization of Methyl Methacrylate

M. M. Al-esaimi^a

^a Chemistry Department, Umm Al Qura University, Faculty of Applied Science, Makkah Al-makarramah, Saudi Arabia

To cite this Article Al-esaimi, M. M.(2000) 'Catalytic Reaction by Hydrotalcites - (I): Polymerization of Methyl Methacrylate', International Journal of Polymeric Materials, 45: 1, 55 — 68

To link to this Article: DOI: 10.1080/00914030008034870

URL: <http://dx.doi.org/10.1080/00914030008034870>

PLEASE SCROLL DOWN FOR ARTICLE

Full terms and conditions of use: <http://www.informaworld.com/terms-and-conditions-of-access.pdf>

This article may be used for research, teaching and private study purposes. Any substantial or systematic reproduction, re-distribution, re-selling, loan or sub-licensing, systematic supply or distribution in any form to anyone is expressly forbidden.

The publisher does not give any warranty express or implied or make any representation that the contents will be complete or accurate or up to date. The accuracy of any instructions, formulae and drug doses should be independently verified with primary sources. The publisher shall not be liable for any loss, actions, claims, proceedings, demand or costs or damages whatsoever or howsoever caused arising directly or indirectly in connection with or arising out of the use of this material.

Catalytic Reaction by Hydrotalcites - (I): Polymerization of Methyl Methacrylate

M. M. AL-ESAIMI

*Umm Al Qura University, Faculty of Applied Science, Chemistry Department,
Makkah Al-makarramah, P.O. Box 4496, Saudi Arabia*

(Received 26 June 1998)

The synthesis of nickel/chromium hydrotalcite and zinc/iron Hydrotalcites are described. The compounds have been characterized by X-ray powder diffraction (XRD), Infrared spectroscopy (IR), and thermogravimetric analysis (TGA) techniques.

The rate of polymerization of methyl methacrylate (MMA) in the presence of different hydrotalcites at various concentrations of initiator and different temperatures were studied. The activation energies of polymerization were calculated.

Keywords: Hydrotalcites; methyl methacrylate; polymerization; initiation; activation energies

INTRODUCTION

Hydrotalcites are a large group of natural and synthetic clay mineral of current interest because of their application in pharmaceutical science [1]. Calcined hydrotalcite are potentially useful as either catalyst or base catalysts for aldol condensations [2–4], olefin isomerization [5], alkylation [6], aromatization [7], polymerization [8], it can be used also as adsorbents [9–10], and stabilizers for polymers [11]. Their formula can be written as:

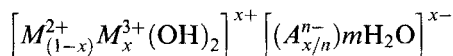

with $M^{2+} = (\text{Mg}, \text{Zn}, \text{Fe}, \text{Ni}, \text{Cu}, \text{or Mn})$, $M^{3+} = (\text{Al}, \text{Fe}, \text{Cr}, \text{or Ga})$, and $A^{n-} (\text{CO}_3^{2-}, \text{SO}_4^{2-}, \text{or NO}_3^-, \text{etc.})$ and $0 < x < 0.33$. However when

considered as derived from brucite, *i.e.*, $\text{Mg}(\text{OH})_2$, this formula may be rewritten as $[\text{Mg}_{0.75}\text{Al}_{0.25}(\text{OH})_2](\text{CO}_3)_{0.125}0.5\text{H}_2\text{O}$. This family of compounds can be structurally characterized as contain of brucite-like Layers [12–13] in which some divalent metal cation have substituted by trivalent ions to forms positively charged sheets. The cationic charge created in the layers is compensated by the presence of hydrated between the stacked sheets [14].

Their thermal decomposition leads to mixtures of pure and mixed oxides that may recover the original layered structure upon rehydration in the presence of several anions. However calcination at high temperatures undergo transformation to highly reactive oxides [15].

EXPERIMENTAL

Materials

All Chemicals are from BDH Chemicals Ltd, England

- (a) Methyl methacrylate was freed from inhibitor, dried over anhydrous sodium sulphate and twice distilled under vacuum before polymerization.
- (b) $\text{Ni}(\text{NO}_3)_2 \cdot 6\text{H}_2\text{O}$, $\text{Cr}(\text{NO}_3)_3 \cdot 9\text{H}_2\text{O}$, $\text{Zn}(\text{NO}_3)_2 \cdot 6\text{H}_2\text{O}$, $\text{Fe}(\text{NO}_3)_3 \cdot 9\text{H}_2\text{O}$, $\text{K}_2\text{S}_2\text{O}_8$, NaOH and Na_2CO_3 .

(a) Preparation of Hydrotalcites

Hydrotalcites were prepared [16] from the gels produced by mixing two solution. Solution (A), containing $M^{+2}(\text{NO}_3)_2 \cdot 6\text{H}_2\text{O}$ (0.5 M) and $M^{+3}(\text{NO}_3)_3 \cdot 9\text{H}_2\text{O}$ (0.1 M) with a molar ratio $M^{+2}/M^{+3} = 5$, while solution (B), containing Na_2CO_3 (0.62 M) and NaOH (0.28 M) so that the molar ratio was equal to 2.2. The precipitation was carried out by dropwise addition of the two solutions at 60°C followed by stirring for 3 hr at 60°C , the resulting precipitate was then cooled to room temperature, filtered and washed with distilled water until the washing were free of nitrate. The products were heated at 80°C for several days.

(b) The Calcined Hydrotalcites

A portion of the solid was submitted to air for 2 h at temperature corresponding to the formation of thermally-stable phases, to study more detail about the nature of the intermediate compounds formed during calcination of these samples.

Polymerization of MMA in Presence of Hydrotalcite Polymerization of MMA with of hydrotalcites were carried out by dissolving the appropriate weight of $K_2S_2O_8$ in distilled water (45 ml) in a 250 ml conical flask into which MMA (4.7 g) was introduced. The hydrotalcites were added and then the flask was stoppered and put in a thermostatic water bath for reaction time. The polymerization was stopped by adding hydroquinone (0.2 w/v monomer). The reaction product was precipitate in a large excess of distilled water then filtered off, and finally dried at 80°C for several days and weighed to determined the rate of polymerization.

Analytical Techniques

Thermogravimetry (TG)

Thermogravimetry (TG) measurements were made with a Mettler 3000 TA thermobalance. The sample (about 10 mg) was heated from 50°C to 800°C at a heating rate of 10°C/min. and under N_2 flow (60 ml/min).

X-Ray Diffraction and IR Studies

X-ray powder diffraction (XRD) patterns were recorded using a Philips APD 1700 white Fe-filtered $W K_\alpha$ radiation.

Infrared spectroscopy absorption studies were carried out in the form of KBr pellets in a (Pye Unicom Infrared spectrophotometer) model (SP 3-100) in the range 4000–600 cm^{-1} .

RESULTS AND DISCUSSION

Characterization of Hydrotalcites

X-ray Diffraction (XRD)

X-ray diffraction (XRD) pattern and the d -spacing of the original hydrotalcite $\text{Ni}^{+2}/\text{Cr}^{+3}$, $\text{Zn}^{+2}/\text{Fe}^{+3}$ and the thermally stable phases are represented in Figures 1a–d and 2a–d and Tables I and II. The studies reveals that when the sample is calcined at 250°C , the material retains its layered structure but with a small decrease in the d -spacing resulting from the loss of interlayer water in Figures 1b–2b. Further calcination at 500°C results in complete destruction of the layered structure and formation of a highly amorphous phase, a mixture of NiCr_2O_4 , ZnFe_2O_4 spinel, NiO , ZnO and Cr_2O_3 , Fe_2O_3 phases were detected in Figures 1c–2c. As calcination temperature is increased to 700°C , the peaks corresponding to the oxides NiCr_2O_4 , ZnFe_2O_4 , NiO , and ZnO phases were detected in Figures 1d–2d with the sharper pattern which means better crystallized for solids phases at that calcination temperature.

Thermal Analysis

Figure 3 represents the DTG curves for the synthesized $\text{Ni}^{2+}/\text{Cr}^{3+}$ and, $\text{Zn}^{2+}/\text{Fe}^{3+}$ hydrotalcite. DTG curves of $\text{Ni}^{2+}/\text{Cr}^{3+}$ hydrotalcite shows two degradation steps at 95°C and 265°C respectively with (%)

TABLE I X-ray powder data for synthetic hydrotalcite

<i>Ni/Cr (rm)</i>		<i>Ni/Cr (250°C)</i>		<i>Ni/Cr (500°C)</i>		<i>Ni/Cr (750°C)</i>	
2θ	d (Å)	2θ	d (Å)	2θ	d (Å)	2θ	d (Å)
4.199	21.026	4.474	19.732	20.800	4.267	18.476	4.798
33.251	2.692	26.325	3.383	37.175	2.417	30.350	2.943
38.374	2.344	33.900	2.641	38.349	2.345	35.740	2.509
40.000	2.252	38.450	2.339	43.250	2.090	37.274	2.410
44.627	2.029	44.699	2.0256	44.624	2.029	38.400	2.342
59.300	1.557	59.702	1.548	62.825	1.478	43.300	2.088
62.750	1.479	61.876	1.498	64.975	1.434	44.650	2.028
65.001	1.434	62.325	1.487	–	–	57.400	1.604
–	–	65.124	1.431	–	–	62.75	1.475
–	–	–	–	–	–	65.099	1.432

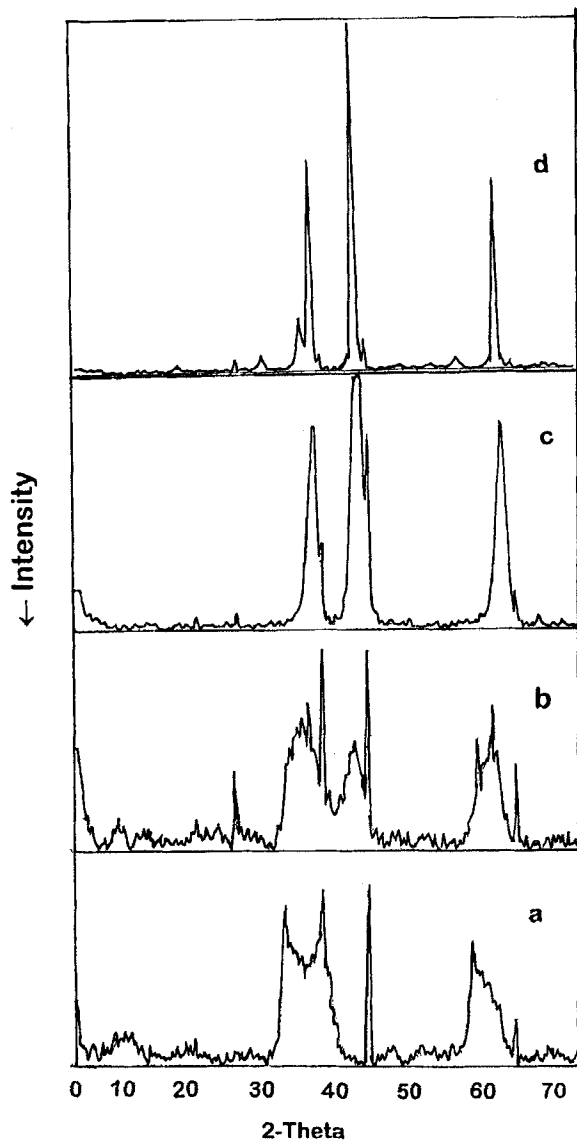

FIGURE 1 X-ray diffraction patterns of Ni/Cr (5/1) at (a) room temp. (b) 250°C (c) 500°C (d) 700°C.

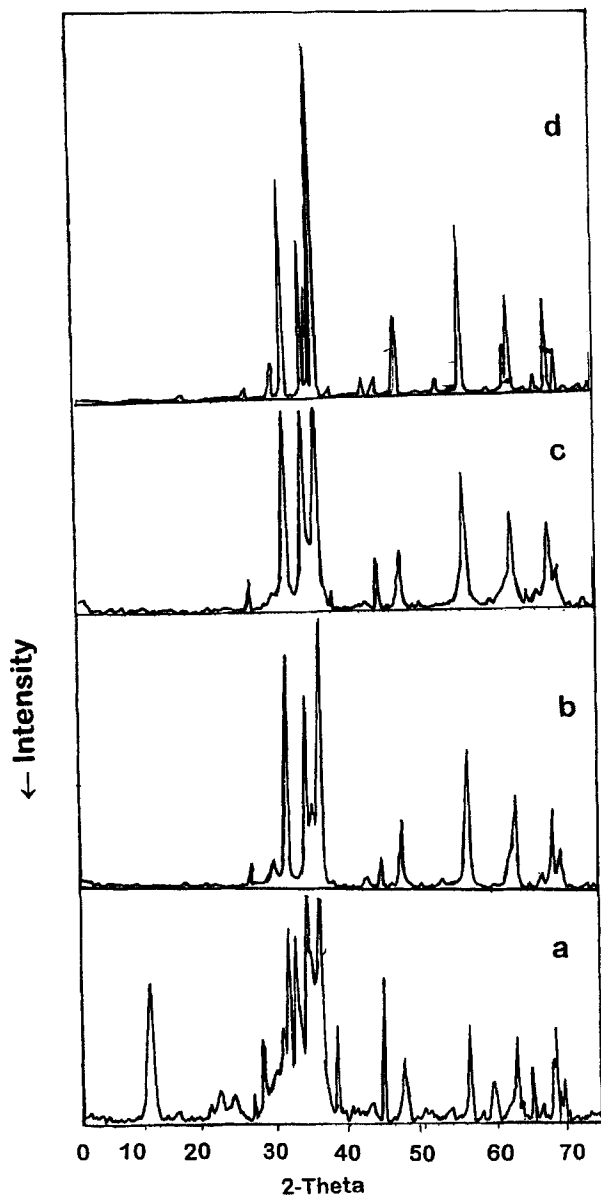

FIGURE 2 X-ray diffraction patterns of Zn/Fe (5/1) at (a) room temp. (b) 250°C (c) 500°C (d) 700°C.

TABLE II X-ray powder data for synthetic hydrotalcite

Zn/Fe (rm)		Zn/Fe (250°C)		Zn/Fe (500°C)		Zn/Fe (700°C)	
2θ	d (Å°)	2θ	d (Å°)	2θ	d (Å°)	2θ	d (Å°)
13.000	6.805	29.850	2.991	29.876	2.988	18.174	4.877
22.174	4.006	34.47	2.599	34.426	2.603	29.975	2.979
28.051	3.178	36.251	2.478	36.250	2.476	34.499	2.560
38.450	2.339	38.400	2.342	42.751	2.113	36.300	2.473
44.651	2.028	44.601	2.029	44.601	2.0299	38.451	2.339
47.599	1.909	47.526	1.912	47.574	1.910	44.670	2.026
56.575	1.625	56.601	1.625	53.100	1.723	47.599	1.909
62.850	1.477	61.174	1.514	62.875	1.477	56.650	1.623
65.026	1.433	65.000	1.434	65.025	1.433	62.924	1.476
66.374	1.4072	66.351	1.408	66.301	1.409	66.425	1.406

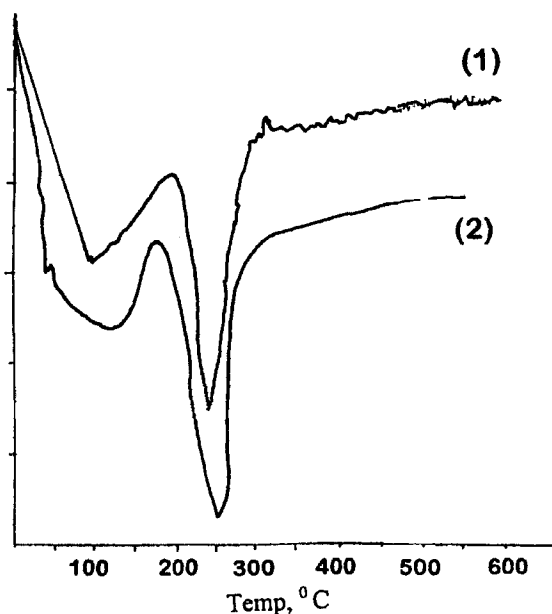

FIGURE 3 DTG analysis for (1) Ni/Cr (5/1) hydrotalcite (2) Zn/Fe (5/1) hydrotalcite.

weight loss of 11.3 and 20.5, respectively, while Zn^{2+}/Fe^{+3} hydrotalcite shows two TG stages at 139°C and 272°C with weight loss percentages of 11.9 and 21.2 respectively. The first peak is ascribed to the removal of water molecules from interlayer space and the second peak is from evolution CO_2 from interlayer carbonate and water

vapor, through condensation of hydroxyl group from the brucite layers [17].

Infrared Spectroscopy

Infrared spectrum for the $\text{Ni}^{2+}/\text{Cr}^{+3}$ and, $\text{Zn}^{+2}/\text{Fe}^{+3}$ hydrotalcites in the range $4000\text{--}600\text{ cm}^{-1}$ have been shown in Figure 4. In $3600\text{--}3000\text{ cm}^{-1}$ region, the spectra shows a broad band which may be attributed to superposition of deformational vibration of the physical adsorbed water [18]. An absorption band at $1605, 1620\text{ cm}^{-1}$ indicates the presence of molecular water [19, 20]. The broad bands of medium intensity close to $1575, 1580\text{ cm}^{-1}$ is probably as a result of the $\text{HO}\dots\text{HO}$, $\text{HO}\dots\text{CO}_3^{2-}$, and $\text{H}_2\text{O}\dots\text{CO}_3^{2-}$ [19, 20]. The bands of $1365, \text{ and } 1385\text{ cm}^{-1}$ may be related to the characteristic vibration of CO_3^{2-} groups [21].

Effect of Weight of Catalyst Table III represents the conversion of MMA to PMMA at different weights of hydrotalcites. It has been shown that the conversion reaches a limiting level using 0.5 g of

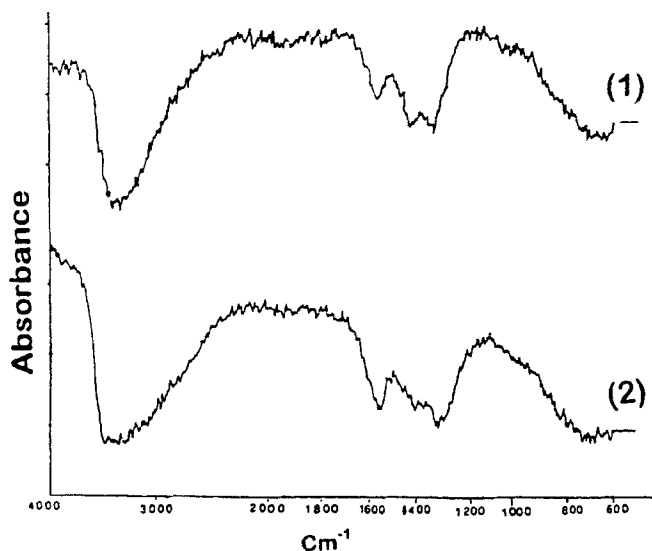

FIGURE 4 IR spectrum ($600\text{--}4000\text{ Cm}^{-1}$) for (1) Ni/Cr hydrotalcite (2) Zn/Fe (5/1) hydrotalcite.

TABLE III Effect of weight of hydrotalcites in polymerization of methyl methacrylate yield (%)

Catalyst wt (g)	Ni/Cr Hydrotalcite yield (%)	Zn/Fe Hydrotalcite yield (%)
0.00	35.4	35.4
0.25 g	58.1	55.3
0.50 g	80.5	76.4
0.75 g	87.7	83.3
1.00 g	89.4	87.6
1.50 g	92.2	90.1

catalyst. Therefore, further experiments were carried out using that limiting level (0.5 g) of Hydrotalcite for the purpose of studying the kinetic of polymerization.

Kinetic of Polymerization Polymerization of methyl methacrylate (MMA) in the presence of Ni/Cr and Zn/Fe hydrotalcites at various temperature by using 0.01, 0.02, and 0.03 mol/l of $K_2S_2O_8$, for various periods are represents in Figures 5–7. The conversion were calculated using the equation:

$$\text{Conversion (\%)} = \frac{C_p - C}{M} \times 100$$

where C_p , C , and M are the weights of hydrotalcite-polymer composite, clay, and the monomer, respectively.

It was found that the rate of polymerization increase as a result of increasing the temperature and initiator concentrations. The rate of polymerization of MMA was higher in presence of Ni/Cr hydrotalcite than in the Zn/Fe hydrotalcite. It seems that the catalytic effect of Hydrotalcites are attributed to the formation of an addition product with potassium persulphate, which may be active enough to increase the rate of polymerization of MMA. Therefore, the catalytic effect of hydrotalcites is attributed to the formation of active complex with the initiator, which increases the rate of polymerization more, than $K_2S_2O_8$ alone. This explanation was found to be in agreement with the polymerization of MMA in the presence of montmorillonite which mentioned elsewhere [22]. It was found that the formation of an addition product between the montmorillonite powder and the initiator increases also the rate of polymerization of MMA [22].

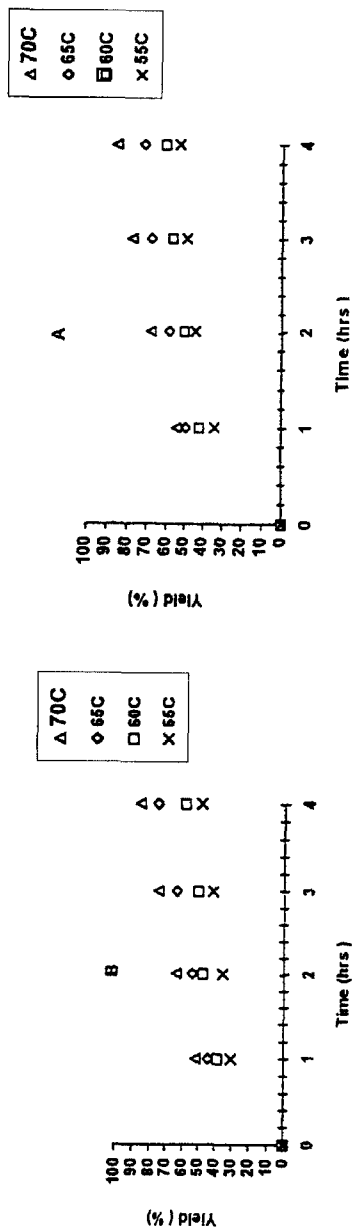

FIGURE 5 Polymerization of MMA with 0.01 mol/L $K_2S_2O_8$: (a) MMA + Cr/Ni; (b) MMA + Fe/Zn at different temperatures.

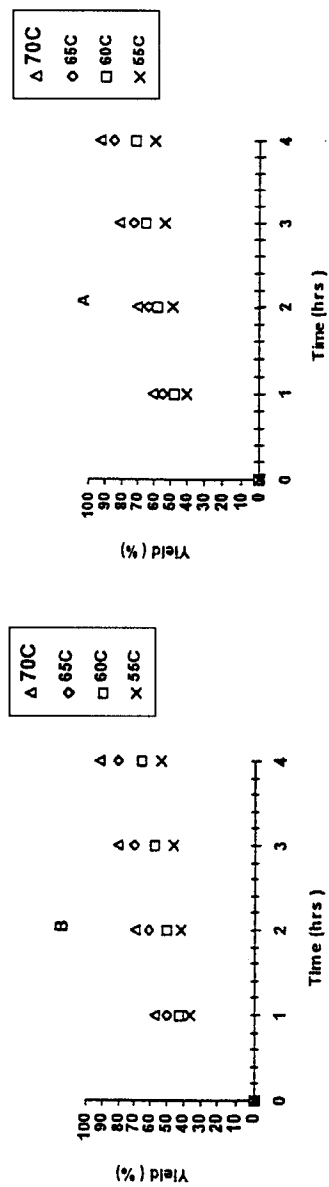

FIGURE 6 Polymerization of MMA with 0.02 mol/L $K_2S_2O_8$: (a) MMA + Cr/Ni; (b) MMA + Fe/Zn at different temperatures.

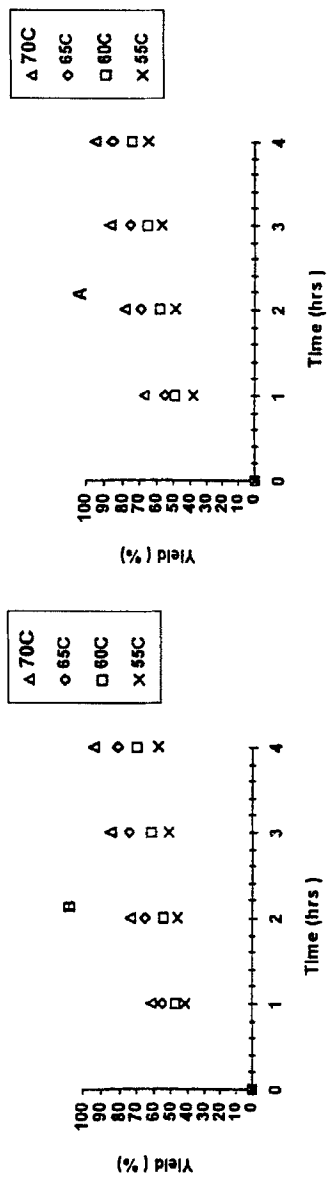

FIGURE 7 Polymerization of MMA with 0.03 mol/L $K_2S_2O_8$: (a) MMA + Cr/Ni; (b) MMA + Fe/Zn at different temperatures.

TABLE IV Activation energies of polymerization of MMA with hydrotalcites (E_a /KJ mole⁻¹)

$K_2S_2O_8$ concentration (mol/l)	Ni-Cr hydrotalcite	Zn-Fe hydrotalcite
0.01	44.7	41.1
0.02	33.5	30.8
0.03	21	15.5

Activation Energy of Polymerization Apparent activation energy, E_a was calculated from initial rate of polymerization of MMA with two different Hydrotalcites, at 55°C, 60°C, 65°C and 70°C. Plots of $\ln k$ VS. $1/T$ were made so the activation energies could be determined by using Arrhenius relationship. Table IV represents the activation energies of polymerization of MMA. E_a is higher in Ni/Cr hydrotalcite than in Zn/Fe Hydrotalcite, and at higher concentration of initiator, E_a decreases.

Acknowledgment

The author wishes to express his thank to the Deputy ministry of minerals resources (Jeddah), ministry of petroleum and minerals resources (Saudi Arabia) for XRD measurements of the hydrotalcite samples.

References

- [1] Climent, M. J., Corma, A., Iborra, S. and Primo, J., *J. Catal.*
- [2] Reichle, W. T. (1985). *J. Catal.*, **94**, 547.
- [3] Corma, A., Fornes, V., Martin Aranda, R. M. and Rey, F. (1992). *J. Catal.*, **134**, 58.
- [4] Cavani, F. and Vaccari, A. (1991). *A. Catal. Today*, **11**, 1.
- [5] Sharper, H. S., Berg-Slot, J. J. and Stork, W. H. J. (1989). *Appl. Catal.*, **54**, 79.
- [6] Velu, S. and Swamy, C. S. (1994). *Appl. Catal., A*, **119**, 241.
- [7] Davis, R. J. and Derouane, E. G. (1991). *J. Catal.*, **132**, 269.
- [8] Laycock, D. E., Collacott, R. J., Skelton, D. A. and Tchir, M. T. (1991). *J. Catal.*, **130**, 354.
- [9] Meyn, M., Beneke, K. and Lagaly, G. (1990). *Inorg. Chem.*, **29**, 5201.
- [10] Miyata, S. (1983). *Clays & Clay Minerals*, **31**, 305.
- [11] Reichle, W. T. *Chemtech.*, January, 1986, p. 56.
- [12] Allmann (1968). *Acta Crystallogr.*, **B24**, 972.
- [13] Idem Neues, Jb. (1969). *Min. Mh.* H12, p. 552.
- [14] Constantino, V. R. L. and Pinnavaia, T. J. (1995). *Inorg. Chem.*, **34**, 883.

- [15] Labajos, F. M., Malet, P., Rives, V. and Ulibarri, M. A. (1995). *3rd GIPS Inorganic Chemistry*, Italy.
- [16] Kannan, S., Velu, S., Ramkumar, V. and Swamy, C. S. (1995). *J. Mater. Sci.*, **30**, 1462.
- [17] Del Arco, M., Galiano, M. V. G., Rives, V., Trujillano, R. and Malet, P. (1996). *Inorg. Chem.*, **35**, 6362.
- [18] Allegra, G. and Ronca, G. (1993). *Acta Crystallogra.*, A341006.
- [19] Trifiro, F. and Vaccaci, A. (1985). *J. Catal.*, **85**, 260.
- [20] Sato, T., Wakayashi, T. and Shimada, M. (1986). *Ind. Eng. Prod. Res. Dev.*, **25**, 99.
- [21] Allmann, A. (1970). *Chimia*, **24**, 99.
- [22] Al-Esaimi, M. M. (1997). *J. Appl. Polym. Sci.*, **64**, 367.